



For certified companies

a member of **DAIKIN** group

# ROTEX

## Instruction manual

### ROTEX

• RDS2

Solar pressure station

🛒 162049

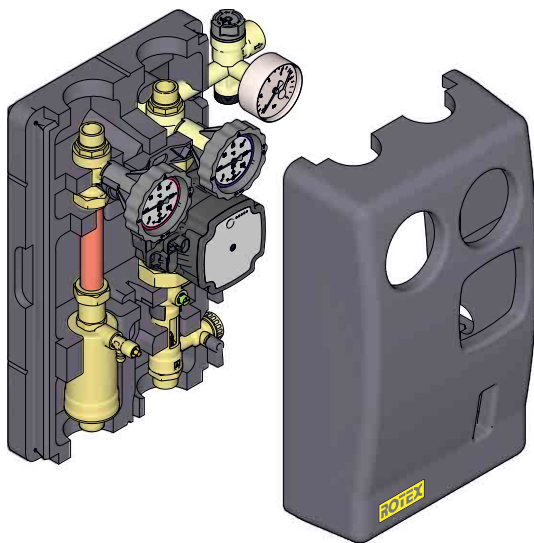

- 👉 Read manual before use!
- 👉 Observe all safety information!
- 👉 Keep manual for future use!

# CE

GB

Output 06/2015

# Table of contents

1	This instruction manual .....	4
1.1	Precautions.....	4
2	Safety .....	5
2.1	Intended use .....	5
2.2	Predictable incorrect application .....	5
2.3	Safe handling.....	5
2.4	Staff qualification.....	6
2.5	Modifications to the product .....	6
2.6	Usage of spare parts and accessories .....	6
2.7	Liability information .....	7
3	Product description .....	8
4	Technical specifications .....	10
4.1	Approvals, tests and conformities .....	12
5	Transport and storage.....	12
6	Mounting and commissioning.....	12
6.1	Mounting ROTEX RDS2 .....	13
6.2	Connecting ROTEX RDS2 .....	15
6.3	Electrical connection .....	18
6.4	Commissioning ROTEX RDS2.....	18
7	Operation.....	20
7.1	Reading mark at flow meter .....	20
7.2	Venting the system .....	21

8	Maintenance .....	22
9	Troubleshooting .....	22
10	Decommissioning, disposal.....	24
11	Warranty .....	24
12	Copyright .....	28

# 1 This instruction manual

This instruction manual is part of the product.

- ▶ Read this manual before using the product.
- ▶ Keep this manual during the entire service life of the product and always have it readily available for reference.
- ▶ Always hand this manual over to future owners or users of the product.

## 1.1 Precautions

---

**WARNING** Type and source of the hazard are shown here.

**WORD**



- ▶ Precautions to take in order to avoid the hazard are shown here.
- 

There are three different levels of warnings:

Warning word	Meaning
<b>DANGER</b>	Immediately imminent danger! Failure to observe the information will result in death or severe injuries.
<b>WARNING</b>	Possibly imminent danger! Failure to observe the information may result in death or severe injuries.
<b>CAUTION</b>	Dangerous situation! Failure to observe the information may result in minor or severe injuries as well as damage to property.

## 2 Safety

### 2.1 Intended use

The solar pump assembly ROTEX RDS2 may only be used to circulate the following liquids in intrinsically safe, closed, solar systems.

- Standard heat transfer fluids (solar liquids) suitable for solar systems such as water-glycol mixtures

The integrated safety group assembly serves to secure against excessive pressure.

Any use other than the application explicitly permitted in this instruction manual is not permitted.

### 2.2 Predictable incorrect application

The solar pump assembly PrimoSol® must never be used in the following cases:

- Operation with swimming pool water
- Use with adherent, corrosive or flammable fluids
- Temperatures in excess of or below the permissible temperatures and pressures, see table 1, page 11

### 2.3 Safe handling

This product represents state-of-the-art technology and is made according to the pertinent safety regulations. Each product is subjected to a function and safety test prior to shipping.

- ▶ Operate the product only when it is in perfect condition. Always observe the operating instructions, all pertinent local and national directives and guidelines as well as the

applicable safety regulations and directives concerning the prevention of accidents.

---

**WARNING**    **Severe burns or death caused by mains voltage (AC 230 V, 50 Hz) in the pump head.**



- ▶ Avoid any contact of the pump head with water or solar liquid.
  - ▶ Disconnect the mains voltage supply before opening the pump head or before performing maintenance and cleaning work and make sure it cannot be switched on.
  - ▶ Do not tamper with the pump head in any way whatsoever.
- 

## 2.4 Staff qualification

The product may only be mounted, commissioned, operated, maintained, decommissioned and disposed of by qualified, specially trained staff.

Electrical work may only be performed by trained electricians and in compliance with all applicable local and national directives.

## 2.5 Modifications to the product

Changes or modifications made to the product by unauthorised persons may lead to malfunctions and are prohibited for safety reasons.

## 2.6 Usage of spare parts and accessories

Usage of unsuitable spare parts and accessories may cause damage to the product.

- ▶ Use only genuine spare parts and accessories of the manufacturer.

## 2.7 Liability information

The manufacturer shall not be liable in any form whatsoever for direct or consequential damage resulting from failure to observe the technical instructions, guidelines and recommendations.

The manufacturer or the sales company shall not be liable for costs or damages incurred by the user or by third parties in the usage or application of this product, in particular in case of improper use of the product, misuse or malfunction of the connection, malfunction of the product or of connected products. The manufacturer or the sales company shall not be liable for damage whatsoever resulting from any use other than the use explicitly permitted in this instruction manual.

The manufacturer shall not be liable for misprints.

### **3 Product description**

Complete, pre-assembled and tightness-tested solar pump assembly with all required safety and functional components, including form-fit heat insulation. The heat insulation is also used to package the product for safe transport.



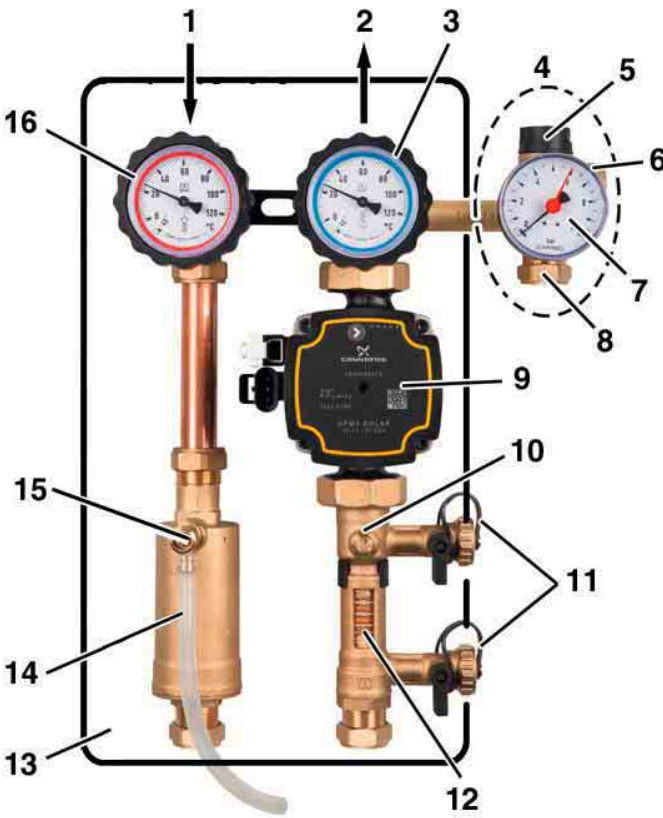

- 1 Flow
- 2 Return
- 3 Ball valve, blue, can be shut off, with gravity brake and thermometer
- 4 Safety group assembly
- 5 Safety valve
- 6 Discharge opening
- 7 Pressure gauge with mounting valve
- 8 Connection for expansion vessel.
- 9 Circulation pump
- 1 Shut-off
- 0
- 1 Filling and flushing valves
- 1 Flow meter
- 2
- 1 Heat insulation
- 3
- 1 Vent pot
- 4
- 1 Vent valve with hand wheel
- 5
- 1 Ball valve, red, can be shut off, with gravity brake and thermometer
- 6

*Fig. 1: ROTEX RDS2, flow and return with filling and flushing valves and vent pot*

## 4 Technical specifications

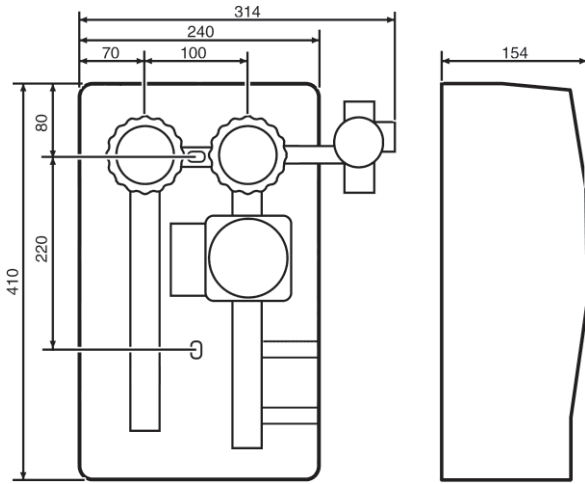

*Fig. 2: Dimensions [mm] ROTEX RDS2*

Table 1: Technical specifications

Parameter	Value
System connection	Compression fitting DN 22
<b>General specifications</b>	
Weight	Max. 5.5 kg
Material of fittings	Brass CW617N
Material heat insulation	Polypropylene EPP
System pressure	Max. 6 bar
<b>Operating temperature range</b>	
Ambient	Max. 40 °C
Medium	Max. 120 °C, short-term max. 160 °C
<b>Flow meter</b>	
Pump connection	Pump side with flange and union nut G1½.
Measuring range	2-12 l/min
<b>Combination valve red (flow)</b>	
Range	0 °C to +120 °C
<b>Combination valve blue (return)</b>	
Pump connection	Pump side with flange and union nut G1½.
Range	0 °C to +120 °C
<b>Safety group assembly</b>	
Connection for expansion vessel	G¾ for flex pipe, flat-sealing with union nut
Safety valve	6 bar
Pressure gauge	Ø 63 mm, 0-10 bar

## 4.1 Approvals, tests and conformities

The safety valve of the safety group assembly complies with Pressure Equipment Directive (97/23/EC).

See enclosed operating instructions of the manufacturer of the circulation pump for circulation pump.

## 5 Transport and storage

---

**CAUTION**    **Damage to the product due to improper transport.**



- ▶ Do not throw or drop the product.
- 

**CAUTION**    **Damage to the product due to improper storage.**



- ▶ Protect the product from shock when storing it.
  - ▶ Store the product in a clean and dry environment.
- 

## 6 Mounting and commissioning

---

**WARNING**    **Scalding due to hot solar liquid and escaping steam.**



- ▶ Take all necessary measures during mounting, commissioning and maintenance of the solar pump assembly to ensure that hot liquid does not pose any hazard to persons.
- 
- ▶ Install the solar pump assembly in such a way that no steam can get into the expansion vessel during stagnation.
  - ▶ If the expansion vessel is mounted at the same height as the solar pump assembly or higher than the solar pump assembly, install a heat trap siphon.
-

- ▶ During heating up, liquid must be able to escape via the discharge line of the safety valve (no obstructions). Install the safety valve in such a way that it **cannot be shut off**.  
Do not install shut-off valves, filters or similar equipment.
- ▶ Install the solar pump assembly in such a way that no external forces can act on the components after it has been installed.
- ▶ Do not overheat the components by welding or soldering work performed on the system. Install the solar pump assembly after completion of such welding or soldering work.
- ▶ Thoroughly flush the pipes prior to installing the solar pump assembly. Impurities such as weld beads, hemp or metal chips cause leaks of the safety valve and the check valves.
- ▶ Verify that the nominal pressure of the solar pump assembly corresponds to the specification value of the system.
- ▶ Verify that the liquid in the system and the application area of the solar pump assembly are compatible.

## 6.1 Mounting ROTEX RDS2

- Sealing surfaces have been checked for cleanliness and damage.
- All pipe ends are perpendicular and have been deburred.

ROTEX RDS2 is delivered ready to be installed. Do not disassemble parts.

1. Remove the upper insulation.
2. Hold ROTEX RDS2 with the lower insulation to the wall (align with a level) and mark two positions.

3. Drill holes ( $\varnothing$  10 mm) at the position of the two marks and insert the enclosed dowels. Screw the long hanger bolt into the top hole, the short hanger bolt into the bottom hole.
4. Fit ROTEX RDS2 with the bottom insulation and secure it with a washer and a nut.
5. Connect the pipes of the solar circuit to the connections of the fittings.
6. Refit the upper insulation.

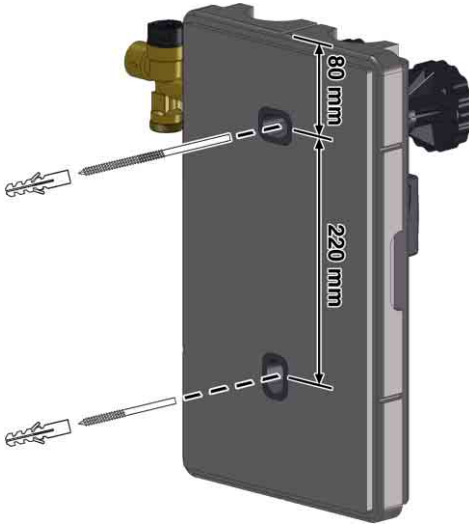

*Fig. 3: Mounting ROTEX RDS2*

## 6.2 Connecting ROTEX RDS2

1. Connect the pipes of the solar circuit to the connections of the fittings.
2. Connect the pipe or flex pipe of the expansion vessel to the safety group assembly.

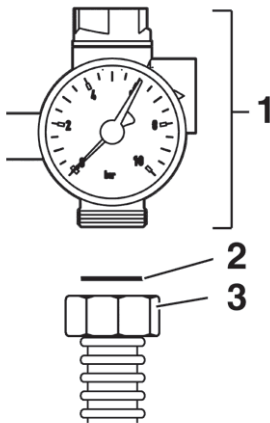

- 1 Safety group assembly
- 2 Flat gasket
- 3 Flex pipe, flat-sealing

*Fig. 4: Connection flex pipe G $\frac{3}{4}$*

3. Connect the discharge line of the safety valve to the safety group assembly, see below.
4. Connect the unit electrically, see chapter 6.3, page 18.

### 6.2.1 Discharge line of the safety valve

The discharge opening is designated by an arrow on the valve body.

---

**WARNING**



**Injuries and hazard of scalding due to hot liquid or steam escaping via the discharge opening.**

- ▶ Install the discharge line in such a way as to avoid any damage or injuries due to escaping liquid and that the liquid can be safely collected in a suitable collector tank for solar liquid.
- 

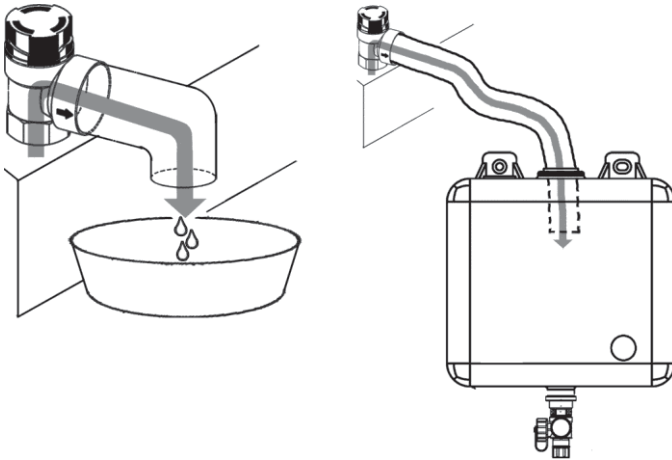

*Fig. 5: Discharge line with container or collector tank for solar liquid*

- ▶ The discharge line must have a gradient; its cross section must have at least the same cross section as that of the discharge opening.
- ▶ The length of the discharge line must not exceed 2 m; the maximum number of elbows is 2.
- ▶ The discharge line must be accessible and observable.



- ▶ Drain the liquid discharged via the discharge line into a container that can hold the total capacity of the system. The discharged liquid must be collected and returned to the system or disposed of by a specialised company. **Do not drain** the discharged liquid **into the sewage system**.

## 6.3 Electrical connection

- ☑ Mains voltage is interrupted and cannot be switched on.
- 1. Connect the circulation pump described in the enclosed operating instructions.
- 2. Route the connection cable of the circulation pump through a cable duct to the bottom and connect it to the solar controller. Observe the operating instructions of the solar controller.
- 3. Standard shielded cable 3 x 1.5 mm<sup>2</sup> and up to Ø 10 mm can be used to extend the connection cable.

## 6.4 Commissioning ROTEX RDS2

In the case of ROTEX RDS2, filling is possible via the filling and flushing valves at the flow meter.

1. Attach a label in the vicinity of the discharge line or to the safety valve with the following text:  
**"For safety reasons, liquid must be able to escape via the discharge line during heating. Do not shut off!"**
2. Verify that all connections are tight.
3. Set both ball valves to 45° position.



- 0° **Operation** – open in the direction of flow of the solar liquid
- 45° **Commissioning, filling, venting, flushing** – both sides open (backflow preventer not active)
- 90° **Maintenance** – closed

*Fig. 6: Ball valves*

4. Screw hose connectors to the filling and flushing valves and connect hoses. Open the shut-off valves (1, 2) and close the shut-off (3) for filling.

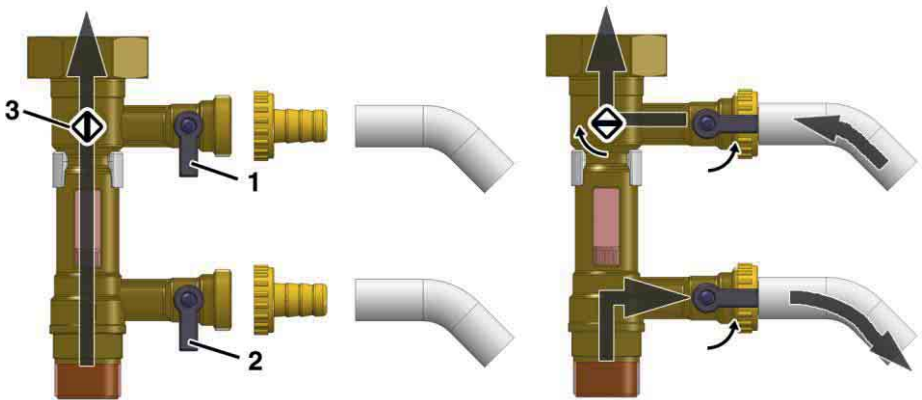

5. Fill the system with solar liquid via the upper valve (1).
  6. As soon as solar liquid escapes via valve (2), close this valve.
  7. Apply pressure to the system.
  8. Close the upper valve. Turn back the shut-off (3).
  9. Vent the system, see chapter 7.2, page 21.
  10. Set both **ball valves to 0° position**.
  11. Fit the upper part of the heat insulation onto the fitting group.
  12. The heat insulation of the pipes should reach into the corresponding recess of the heat insulation of the solar pump assembly.
- ↙ The solar pump assembly is ready for operation.

## 7 Operation

For safety reasons, liquid must be able to escape via the discharge line of the safety valve during heating.

- ▶ **Do not shut off** the safety valve.
- ▶ If the safety valve has responded, check the system prior to resuming operation.

Proper operation is only possible if the ball valves are open (0° setting, see fig. 6, page 18).

### 7.1 Reading mark at flow meter

The lower edge of the float is the reading mark at the flow meter.

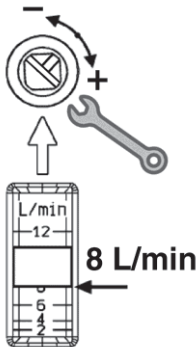

*Fig. 7: Reading mark at flow meter*

## 7.2 Venting the system

**WARNING** Hazard of scalding due to hot liquid or steam escaping at the vent valve or due to contact with the vent pot.



- ▶ Only vent the system if the red thermometer shows a temperature value of  $< 50\text{ }^{\circ}\text{C}$ .

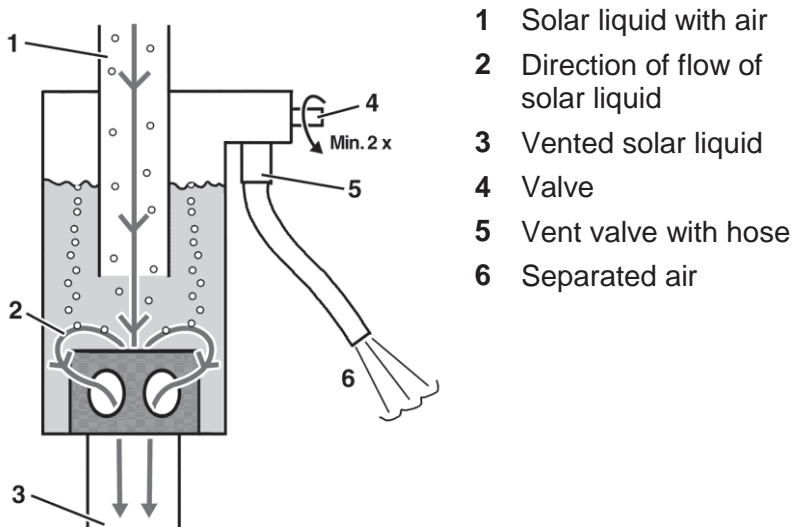

*Fig. 8: Function principle vent pot*

The solar liquid flows into the vent pot from the top (1). The solar liquid hits the surface, air bubbles are separated and rise to the top. The air collects in the upper part of the vent pot. This air can be removed from the system by manual venting:

1. Put the hose of the vent valve (5) into a collection receptacle.
2. Open valve (4).
- ☞ The separated air escapes from the vent pot.
3. Close the valve as soon as solar liquid escapes.

## 8 Maintenance

*Table 2: Maintenance times*

When	Activity
Flow meter can no longer be read	▶ Drain, flush and fill the system
Circulation pump defective	▶ Replace the circulation pump, see below

### 8.1.1 Replace circulation pump

1. Close the shut-off at the flow meter and set the blue ball valve to 90° position.
2. Replace the circulation pump.
3. Open the shut-off at the flow meter and set the blue ball valve to 0° position.
4. In the case of pressure loss in the system, refill solar liquid and re-commission the system.

## 9 Troubleshooting

Repairs may only be performed by specially trained, qualified staff.

- ▶ Observe the enclosed operating instructions in the case of malfunctions of the circulation pump.

*Table 3: Troubleshooting*

Problem	Possible reason	Repair
Noise in the system	Air in the system	▶ vent the system, see chapter 7.1, page 20
	Pump capacity too high	▶ Switch to a lower speed of rotation

Problem	Possible reason	Repair
Noise in the circulation pump	System pressure too low	▶ Increase the system pressure or check the gas volume in the expansion vessel
Circulation pump does not start	Incorrect power supply	▶ Check fuses; check for loose cable terminals
	Circulation pump blocked by deposits in the bearings	▶ Switch to maximum speed of rotation for a short period of time ▶ Unblock the rotor, insert a screwdriver into the groove and rotate manually
	Circulation pump polluted	▶ Dismount and clean circulation pump
	Circulation pump defective	▶ Replace circulation pump
No pressure in the system	Safety valve defective	▶ Replace safety group assembly
	Expansion vessel not tight	▶ Replace expansion vessel
	Leak in the system	▶ Locate the leak and seal it professionally
When the system is drained, no medium escapes via the filling and flushing units	Ball valves and/or shut-off closed	▶ Set ball valves to 45° position and open shut-off: 
Other malfunctions	–	▶ Send the product to the manufacturer

## 10 Decommissioning, disposal

1. Switch off the supply voltage.
2. Dismount ROTEX RDS2 (see chapter 6, page 12, reverse sequence of steps).

---

**INFORMATION ON DISPOSAL** ROTEX RDS2 has an environmentally friendly design. The waste created during disposal can be recycled or thermally treated. The recyclable materials can be sorted and separated.

---



With the environmentally friendly design of ROTEX RDS2, ROTEX meets the requirements for environmentally friendly disposal of the product. The operator is responsible for professional disposal in compliance with all regulations applying at the installation site.

---



The product label means that electrical and electronic products must not be disposed of with normal household waste.

The operator is responsible for professional disposal in compliance with all regulations applying at the installation site.

- Disassembly of the system, handling of solar liquid and other parts may only be performed by appropriately trained professionals.

- Disposal only via a specialised recycling firm.

Contact the installer or the authorities in charge for additional information.

---

## 11 Warranty

The manufacturer's warranty for this product is 24 months after the date of purchase. This warranty shall be good in all countries in which this product is sold by the manufacturer or its authorised dealers.









## 12 Copyright

The manufacturer retains the copyright to these operating instructions. These operating instructions may not be reprinted, translated, copied in part or in whole without prior written consent.

We reserve the right to technical modifications with reference to the specifications and illustrations in this manual.

a member of **DAIKIN** group

# ROTEX

**ROTEX products distributed in UK:**

DAIKIN AIR CONDITIONING UK Ltd.  
The Heights, Brooklands, Weybridge  
KT13 0NY Surrey  
Fon +44 845 641 90 00  
Fax +44 845 641 90 09  
[www.daikin.co.uk](http://www.daikin.co.uk)

**ROTEX Heating Systems GmbH**

Langwiesenstraße 10  
D-74363 Güglingen  
[www.rotex-heating.com](http://www.rotex-heating.com)